



201 N. Champaign St. Bement, Illinois 61813

## COMPRESSOR REPLACEMENT B33=75 30# BYPASS

**Media Type:** Cellulose

Max Working Pressure (psi): 175

Core Collapse Pressure (psid): 80

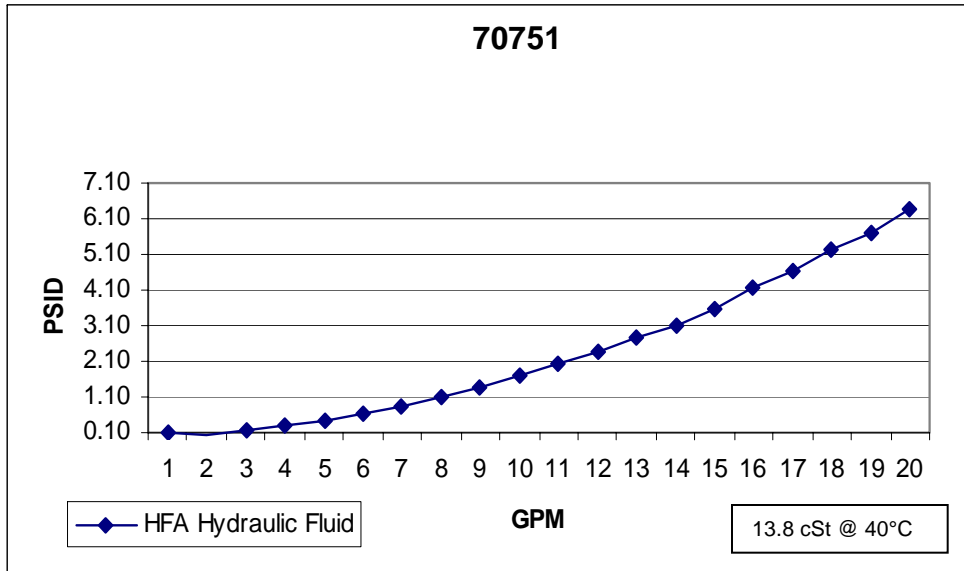

B10=2  
 β14=3  
 β33=75  
 β37=200  
 β46=500

## Technical Data Sheet - 70751

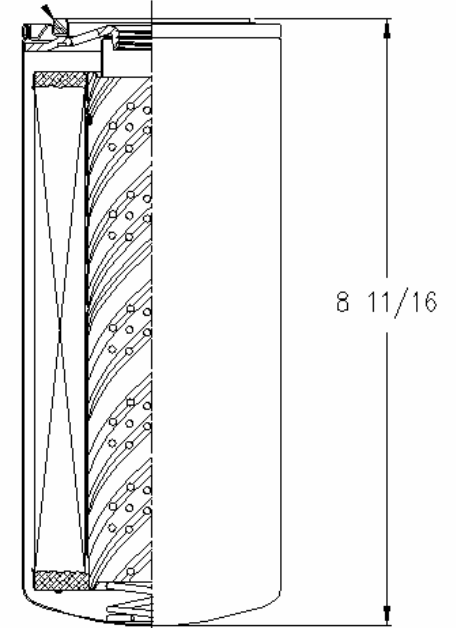
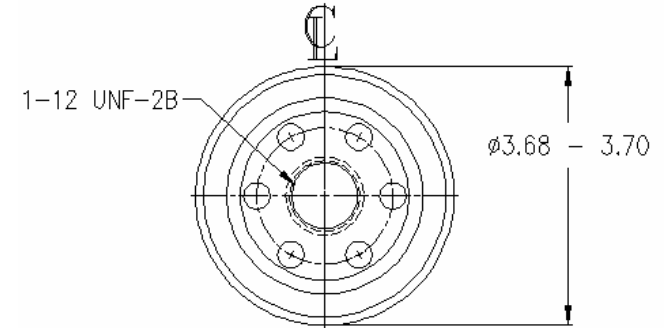

Gasket:  
 I. D. 2 13/32  
 O. D. 2 25/32

**NOTES:**

1. Technical Data subject to change without notice.
2. Tests are conducted with Mobile Aero HFA Aviation Hydraulic Fluid.
3. Filters are not to be used with aviation applications.