



201 N. Champaign St. Bement, Illinois 61813

COMPRESSOR REPLACEMENT B17=75 15# BYPASS

Media Type: Cellulose

Max Working Pressure (psi): 175

Core Collapse Pressure (psid): 80

$\beta_4=2$
 $\beta_6=3$
 $\beta_{14}=34$
 $\beta_{17}=75$
 $\beta_{28}=200$

NOTES:

1. Technical Data subject to change without notice.
2. Tests are conducted with Mobile Aero HFA Aviation Hydraulic Fluid.
3. Filters are not to be used with aviation applications.

jw 02/24/09 Rev A

Technical Data Sheet - 70322

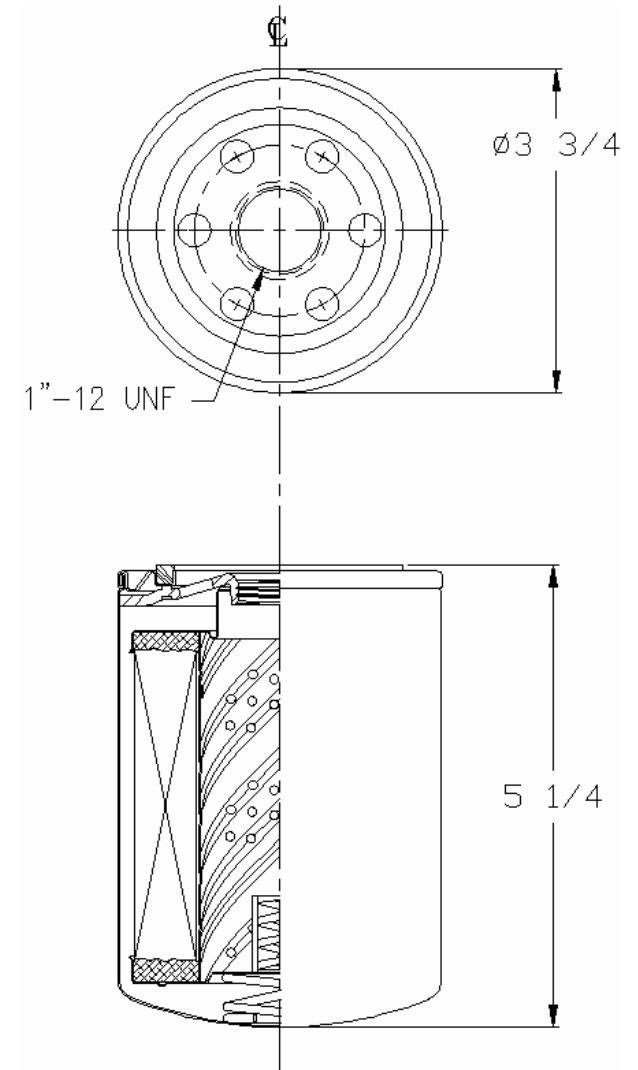

Gasket:

I. D. 2 13/32

O. D. 2 25/32