



201 N. Champaign St. Bement, Illinois 61813

## COMPRESSOR REPLACEMENT B33=75 25# BYPASS

**Media Type:** Cellulose

Max Working Pressure (psi): 175

Core Collapse Pressure (psid): 80

$\beta_{10}=2$   
 $\beta_{14}=3$   
 $\beta_{33}=75$   
 $\beta_{37}=200$   
 $\beta_{46}=500$

### Technical Data Sheet - 70313

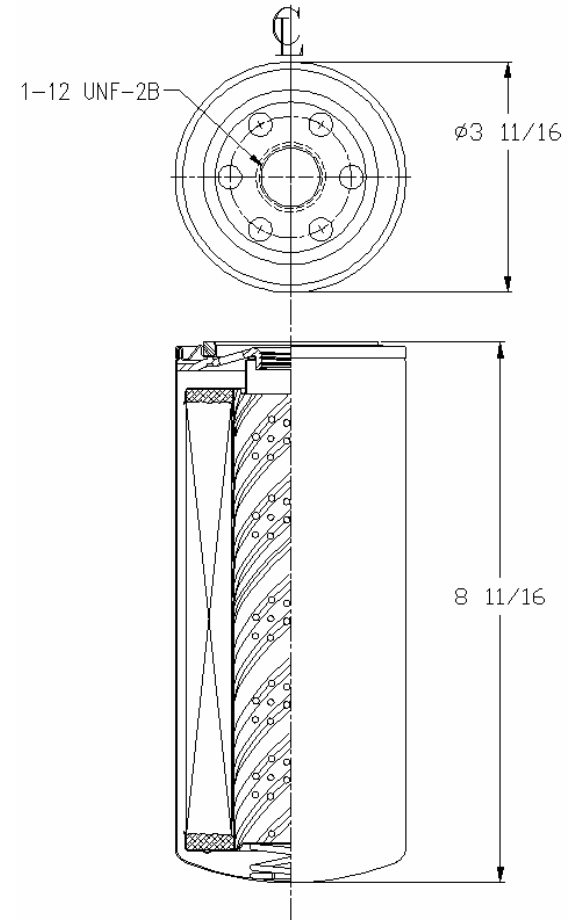

Gasket:

I. D. 2 13/32

O. D. 2 25/32

#### NOTES:

1. Technical Data subject to change without notice.
2. Tests are conducted with Mobile Aero HFA Aviation Hydraulic Fluid.
3. Filters are not to be used with aviation applications.